

KOALA TS300S

Fuse Monitoring System



The Fuse Monitoring System, model TS300S Koala, and its Supervision System are designed to support the monitoring and maintenance activities of medium voltage power distribution networks (13.8kV to 34.5kV).

 **TECSYS**[®]
Smart Power

DESCRIPTION

The Fuse Monitoring System, model TS300S Koala, and its Supervision System are designed to support the monitoring and maintenance activities of medium voltage power distribution networks (13.8kV to 34.5kV). Field installation is performed using a ladder and a maneuver stick, and it can be installed without interruption in the power supply.

The system detects cartridge displacement caused by the fuse link rupture, identifying and storing fuse trigger events in the distribution network, and relaying them in real-time to the Distribution Operation Center. Messages generated by TS300S Koala are transmitted, stored, and managed in a supervisory system. The messages can be securely and reliably accessed for viewing through the Tecsys web platform.

The supervision system can operate simultaneously with thousands of Koalas detectors installed in the power grid. The messages generated by Koalas are translated to Distributed Network Protocol (DNP3), a protocol widely used in Supervisory Control and Data Acquisition (SCADA). The channels, devices, and protocol point maps are configurable according to customer requirements.



Tecsys do Brasil reserves the right to make changes to the content and format of this document without prior notice, aiming for continuous improvement in the information and guidance provided herein. This document is intended solely for product technical information consultation for commercial purposes and may not be reproduced and/or distributed through any means without the express written consent of Tecsys do Brasil.

This document and all information contained therein are the property of Tecsys and/or our suppliers, provided on a confidential basis. They cannot be, in whole or in part, copied, used, duplicated, distributed, or disclosed for any purposes different from what is proposed here without prior written consent from Tecsys.

TECHNICAL SPECIFICATION

TS300S Koala – Fuse Monitoring System

FEATURES

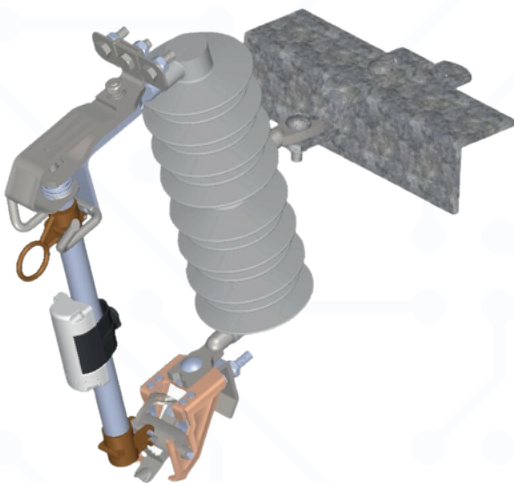

Status notifications Every 24 hours

Immediate events notifications from the distribution network

Use of Lithium Thionyl Chloride (Li-SOCl₂) Battery with 2000mAh charge

Authonomy up to 10-15 years*

3.6V main power source

170mA maximum current

Operational voltage from 13.8 to 34.5kV

Minimum detection currente of 1A

Transmission frequency range: 902.2 to 928MHz

Typical transmission power: +22.5dBm

Operating temperature range: -15 to 65°C

Environmental weather resistant enclosure with IP-65 mechanical protection against dust and water jets, and resistant to ultraviolet irradiation (UVA / UVB)

Dimensions: H: 100 mm; W: 48.64 mm; D: 90 mm (with clamp)

Average equipment weight: 0.144 kg

*Guaranteed 1 messages per day (status) and 10 monthly events

Tecsys do Brasil reserves the right to make changes to the content and format of this document without prior notice, aiming for continuous improvement in the information and guidance provided herein. This document is intended solely for product technical information consultation for commercial purposes and may not be reproduced and/or distributed through any means without the express written consent of Tecsys do Brasil.

This document and all information contained therein are the property of Tecsys and/or our suppliers, provided on a confidential basis. They cannot be, in whole or in part, copied, used, duplicated, distributed, or disclosed for any purposes different from what is proposed here without prior written consent from Tecsys.

TECHNICAL SPECIFICATION

TS300S Koala – Fuse Monitoring System

SOFTWARE AND COMMUNICATION

Wireless communication via Sigfox® network

Supervision system with protocol converter

Data available in DNP3 (Distributed Network Protocol) protocol

Configurable DNP3	One or more communication channels
	One or more slave devices per channel
	Individual points map configuration

Supports synchronous and asynchronous events

Configuration and visualization of data provided on Web Interface

SQL database for events storage and configuration

Tecsys do Brasil reserves the right to make changes to the content and format of this document without prior notice, aiming for continuous improvement in the information and guidance provided herein. This document is intended solely for product technical information consultation for commercial purposes and may not be reproduced and/or distributed through any means without the express written consent of Tecsys do Brasil.

This document and all information contained therein are the property of Tecsys and/or our suppliers, provided on a confidential basis. They cannot be, in whole or in part, copied, used, duplicated, distributed, or disclosed for any purposes different from what is proposed here without prior written consent from Tecsys.

TECHNICAL SPECIFICATION

TS300S Koala – Fuse Monitoring System

TYPICAL APPLICATION

Detection of fuse key opening in Medium Voltage Distribution Network up to 34.5 kV.

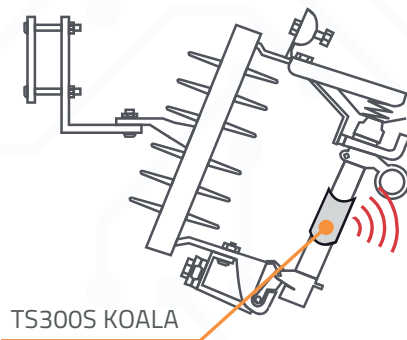

LoRaWAN®

OR



OPERATION CENTER

UPDATED VERSIONS OF THIS GUIDE CAN BE OBTAINED FOR DOWNLOAD ON OUR WEBSITE.